



Roll Groove & Shouldered Fittings

Product Brochure

1300 134 651 | dixonvalve.com.au

Roll Grooved Pipe - Galvanised

Application

- Used for fire hydrant piping systems. Provides water to landing valves, hose reels and hydrant risers. Typically located in stairwells or building cavities, suitable for connection to mains or an independent water supply. Also used for water, slurry and air movement in mining, industrial and irrigation applications.

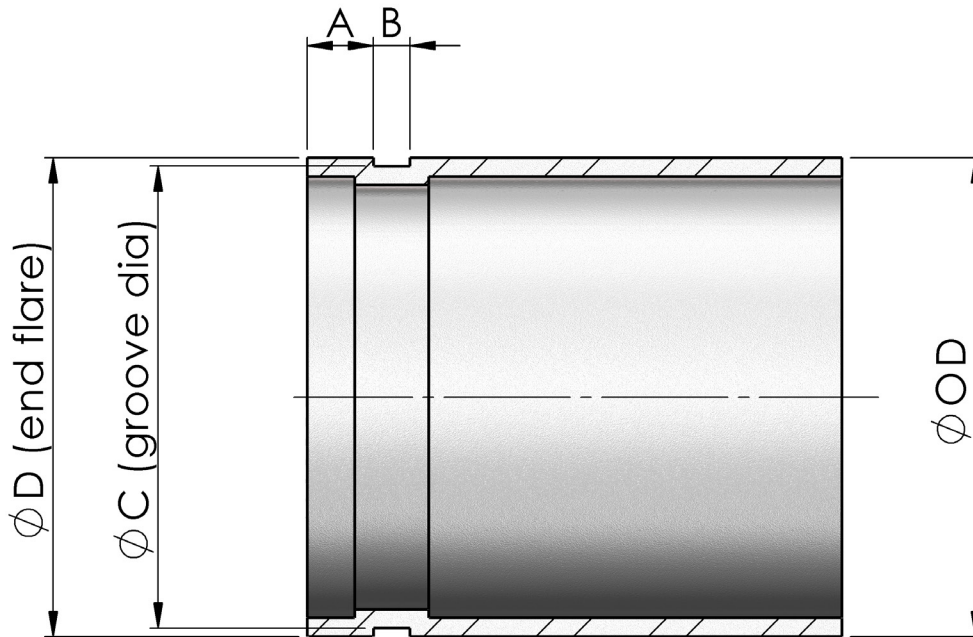

Roll Groove Pipe Specification Table

Size NB		OD (mm)			A (mm)			B (mm)			C (mm)				D (mm)
mm	inch	basic	min	max	basic	min	max	basic	min	max	diameter		circumference		
											min	max	min	max	
32	1¼	42.20	41.80	42.60	15.88	15.12	16.26	7.14	6.38	7.90	38.61	38.99	121.30	122.49	45.00
38	1½	48.30	41.80	48.80	15.88	15.12	16.26	7.14	6.38	7.90	44.71	45.09	140.46	414.65	51.10
50	2	60.30	59.90	60.90	15.88	15.12	16.26	8.74	8.36	9.50	56.77	57.15	178.35	179.54	63.00
65	2½*	76.10	75.40	76.60	15.88	15.12	16.26	8.74	8.36	9.50	71.80	72.26	225.58	227.01	78.70
75	3	88.90	88.40	89.70	15.88	15.12	16.26	8.74	8.36	9.50	84.56	84.94	265.64	266.84	91.40
100	4	114.3	113.8	115.2	15.88	15.12	16.26	8.74	8.36	9.50	109.70	110.08	344.64	345.84	116.8
150	6*	165.1	164.3	166.7	15.88	15.12	16.26	8.74	8.36	9.50	160.22	160.78	503.35	505.11	167.6
200	8	219.1	218.5	220.4	19.05	18.29	19.43	11.91	11.53	12.67	213.89	214.40	671.97	673.56	223.5
250	10	273.1	272.5	274.6	19.05	18.29	19.43	11.91	11.53	12.67	267.63	268.27	840.82	842.81	277.4

* Australian Pipe Size

Medium Wall Pipe AS1074 - Galvanised

Features

- Line marked with all approvals and mill identification every metre for fast visual inspection

Materials

- Hot dipped galvanised to AS/NZS4792

Standards

- AS1074, AS2419.1, AS/NZS4792
- AS1722.1 (Pipe threads), ANSI/AWWA C606-97 (Roll groove)

Approvals

- ActivFire® approved
- UL listed

Galvanised Medium Wall Pipe with BSP Threaded Ends

Size (NB)	OD (mm)	Part Numbers	Length (mtr)	Wall Thickness (mm)	Working Pressure (Bar)	Weight (kg)	Quantity Per Bundle
25	33.4	PMGB-25	6.5	3.2	55	15.9	61
32	42.2	PMGB-32	6.5	3.2	55	20.5	48

Product Group: PI05



Galvanised Medium Wall Pipe with Roll Grooved Ends

Size (NB)	OD (mm)	Part Numbers	Length (mtr)	Wall Thickness (mm)	Working Pressure (Bar)	Weight (kg)	Quantity Per Bundle
32	42.2	PMGG-32	6.5	3.2	55	20.5	48
40	48.3	PMGG-40	6.5	3.2	55	23.7	37
50	60.3	PMGG-50	6.5	3.6	55	33.4	27
65	76.0	PMGG-65	6.5	3.6	55	42.8	19
80	89.0	PMGG-80	6.5	4.0	55	55.6	16
100	114.3	PMGG-100	6.5	4.5	55	80.6	10
150	165.1	PMGG-150	6.5	5.0	55	130.4	7

Product Group: PI05



Light Wall Pipe - Galvanised

Features

- Line marked with all approvals and mill identification every metre for fast visual inspection

Materials

- ASTM A135 standard specification for electric resistance welded (ERW) steel pipe
- Hot dipped galvanised to AS/NZS4792

Standards

- EX6116, AS4118.2.1, AS2419.1
- Roll grooved ends conform to ANSI/AWWA C606-97

Approvals

- ActivFire® approved
- UL listed

Galvanised Light Wall Pipe with Roll Grooved Ends

Size (NB)	OD (mm)	Part Numbers	Length (mtr)	Wall Thickness (mm)	Working Pressure (Bar)	Weight (kg)	Quantity Per Bundle
100	114.3	PFHG-1143-25-RG	6	3.05	35	51.5	10
150	165.1	PFHG-1651-30-RG	6	3.40	35	83.2	7
200	219.1	PFHG-2191-48-RG	6	5.00	35	158.4	5

Product Group: PI03



- The pipe or system working pressures are limited to the published working pressures of the couplings used in the design of the pipeline

Pipe, Pipe Fittings & Welding

Rigid Roll Grooved Couplings - Galvanised

Application

- Suitable for fire sprinkler and hydrant systems. Can also be used for hot water and potable water. Not for use with hydrocarbons such as petroleum, kerosene, and diesel.

Features

- Angle pad design

Materials

- Housing - ductile iron to ASTM-A536
- Hot dip galvanised finish to AS4680
- Standard gasket - EPDM, black

Temperature

- -30°C to 110°C

Model Number

- XGQT7

Comparable To

- Victaulics's No. 005

Approvals

- UL listed, FM approved



Size (NB)	Pipe OD (mm)	Part Numbers	Working Pressure (PSI)
32	42.40	FWG-402R-43	300
40	48.30	FWG-402R-48	300
50	60.30	FWG-402R-60	300
65	76.10	FWG-402R-76	300
80	88.90	FWG-402R-88	300
100	114.3	FWG-402R-114	300
150	165.1	FWG-402R-165	300
200	219.1	FWG-402R-219	300
250	273.1	FWG-402R-273	300
300	323.91	FWG-402R-323	300

Replacement gaskets available refer to page 6

Product Group: CG03

Flexible Roll Grooved Couplings - Galvanised

Application

- Suitable for fire sprinkler and hydrant systems. Can also be used for hot water and potable water. Not for use with hydrocarbons such as petroleum, kerosene, and diesel.
- Flexible couplings allow controlled angular, linear, and rotational movement at each joint. This accommodates expansion/contraction, settling, vibration, and other piping system movement.

Materials

- Housing - ductile iron to ASTM-A536
- Hot dip galvanised finish to AS4680
- Standard gasket - EPDM, black

Temperature

- -30°C to 110°C

Model Number

- XGQT2

Comparable To

- Victaulics's No. 75

Approvals

- UL listed, FM approved



Size (NB)	Pipe OD (mm)	Part Numbers	Working Pressure (PSI)
40	48.3	FWG-75-48	300
50	60.3	FWG-75-60	300
65	76.1	FWG-75-76	300
80	88.9	FWG-75-88	300
100	114.3	FWG-75-114	300
150	165.1	FWG-75-165	300
150 USA	168.3	FWG-75-168	300

Replacement gaskets available refer to page 6

Product Group: CG02

Flexible Heavy-Duty Roll Grooved Couplings - Galvanised

Application

- Suitable for fire sprinkler and hydrant systems. Can also be used for hot water and potable water. Not for use with hydrocarbons such as petroleum, kerosene, and diesel.

Features

- The heavy-duty flexible coupling features a ribbed construction providing working pressures up to 1,000 PSI

Materials

- Housing - ductile iron to ASTM-A536
- Hot dip galvanised finish to AS4680
- Standard gasket - EPDM, black

Temperature

- -30°C to 110°C

Model Number

- Style 11

Comparable To

- Victaulics's No. 77

Approvals

- UL listed, FM approved

Size (NB)	Pipe OD (mm)	Part Numbers	Working Pressure (PSI)
80	88.90	FWG-HDC-88	1000
100	114.3	FWG-HDC-114	1000
150	165.1	FWG-HDC-165	1000
200	219.1	FWG-HDC-219	800
250	273.1	FWG-HDC-250	500
300	323.9	FWG-HDC-300	500

Replacement gaskets available refer to page 6

Product Group: CG04



Grooved Flexible Transition/Reducing Coupling - Galvanised

Application

- Transition couplings are designed to join 150NB Australian Standard size pipe, valves and fittings with OD mm to 150NB API (USA specification) size pipe valves and fittings with OD 168.3mm.

Materials

- Housing - ductile iron to ASTM-A536
- Hot dip galvanised finish to AS4680
- Standard gasket - EPDM, black

Temperature

- -30°C to 110°C

Size (NB)	Pipe OD (mm)	Part Number	Working Pressure (PSI)
165.1 x 168.3	165.1	FWG-402R-165-168	300

Replacement gaskets available refer to page 6

Product Group: CG02



Q

Gasket for Roll Grooved Couplings

Features

Nitrile Rubber

- For use with petroleum products, vegetable oils, mineral oils, and air contaminated with petroleum oils
- Not for use with hot water
- Temperature -31°C to 80°C

EPDM

- For use with water, dilute acids, alkalis, salts and many chemical services not involving hydrocarbons, oils or gases
- Not for use with hydrocarbons
- Temperature -30°C to 110°C



Size (NB)	Pipe OD (mm)	Part Numbers	
		Nitrile Buna	EPDM
40	48.3	GAS-RG-N40	G150E
50	60.3	GAS-RG-N50	GAS-RG-60-E
65 USA	73.0	GAS-RG-N65-73	G250E
65	76.1	GAS-RG-N65	GAS-RG-76-E
80	88.9	GAS-RG-N80	GAS-RG-88-E
100	114.3	GAS-RG-N100	GAS-RG-114-E
150	165.1	GAS-RG-N150	GAS-RG-150-E
150 USA	168.3	G600T	G600E
200	219.1	GAS-RG-N200	GAS-RG-219-E
250	273.1	G1000T	G1000E
300	323.9	GAS-RG-N300	G1200E

Product Group: CA02 Product Group: CA03

Gasket Lube - Roll Grooved Couplings

Application

- Specifically formulated where rubber gaskets are fitted in hot, dry, and wet weather also used in areas where high levels of water quality are not required such as sewerage, irrigation, and fire control systems. A consistent high quality joint is achieved.
- Incorrect lubricants, such as grease, can affect the life and effectiveness of a rubber gasket and also prevent correct positioning of the gasket which can cause joint leakage. It contains an approved bactericide which makes it safe to use with potable water.

Features

- Water soluble emulsion, excess lubricant is quickly removed from pipe systems when the system is flushed
- No detrimental effect on the natural synthetic rubbers used in gasket materials

Standards

- AS4020-1999
- Accredited under the MP 52 spec 014. Licence No. W104



Part Number	Size
FFS-RGLUBE	500g Product Group: HP02

Grooved End Fittings - Galvanised

Application

- A grooved piping system is a robust and long-lasting solution, ideal for situations where flanged connections or welding might be impractical. Tees and elbows are incorporated to redirect flow, while caps provide an endpoint. Grooved piping is versatile and well-suited for a range of applications, including fire protection, water transmission and treatment, and irrigation systems.

Materials

- Ductile iron to ASTM A536
- Hot dip galvanised finish to AS4680

Approvals

- UL listed, FM approved

Grooved 90° Elbows - Galvanised

Comparable To

- ¹Victaulics's No. 001 - sizes 250NB & 300NB

Model Number

- XGQT01

Size (NB)	Pipe OD (mm)	Part Numbers	Working Pressure (PSI)	Centre-to-End (mm)
32	42.4	FWG-10-42S	300	60
40	48.3	FWG-10-48S	300	60
50	60.3	FWG-10-60S	300	70
65	76.1	FWG-10-76S	300	76
80	88.9	FWG-10-88S	300	76
100	114.3	FWG-10-114S	300	102
150	165.1	FWG-10-165S	300	140
150 USA	168.3	FWG-10-168	300	140
200	219.1	FWG-10-219S	300	175
250	273.1	FWG-10-273S ¹	300	215
300	323.9	FWG-10-323S ¹	300	245

Product Group: CG01



Grooved 45° Elbows - Galvanised

Comparable To

- Victaulics's No. 003 - sizes 32NB - 200NB
- ¹Victaulics's No. 11 - sizes 250NB & 300NB

Model Number

- XGQT02

Size (NB)	Pipe OD (mm)	Part Numbers	Working Pressure (PSI)	Centre-to-End (mm)
32	42.4	FWG-11-42S	300	44
40	48.3	FWG-11-48S	300	44
50	60.3	FWG-11-60S	300	51
65	76.1	FWG-11-76S	300	57
80	88.9	FWG-11-88S	300	64
100	114.3	FWG-11-114S	300	76
150	165.1	FWG-11-165S	300	89
150 USA	168.3	FWG-11-168	300	140
200	219.1	FWG-11-219S	300	108
250	273.1	FWG-11-273S ¹	300	121
300	323.9	FWG-11-323S ¹	300	133

Product Group: CG01

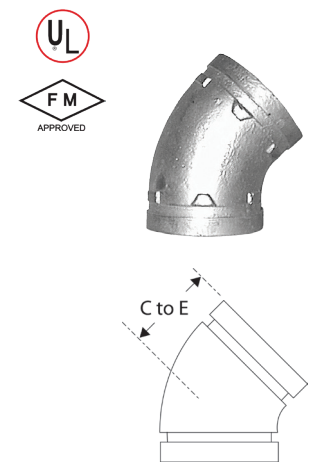

Grooved 22.5° Elbows - Galvanised

Comparable To
 • Victaulic's No. 12

Model Number
 • XGQT07

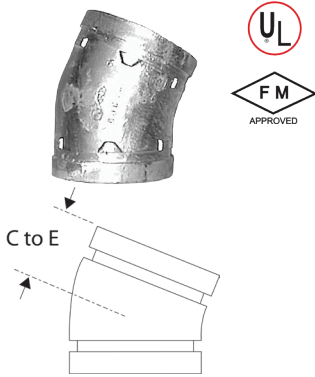

Size (NB)	Pipe OD (mm)	Part Numbers	Working Pressure (PSI)	Centre-to-End (mm)
100	114.3	FWG-22-114	300	73
150	165.1	FWG-22-165	300	79
200	219.1	FWG-221/2-219	300	197

Product Group: CG01

Grooved 11.25° Elbows - Galvanised

Comparable To
 • Victaulic's No. 13

Model Number
 • XGQT07

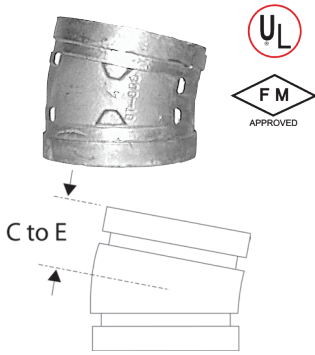

Size (NB)	Pipe OD (mm)	Part Numbers	Working Pressure (PSI)	Centre-to-End (mm)
80	88.9	FWG-111/4-88	300	38
100	114.3	FWG-111/4-114	300	44
150	165.1	FWG-111/4-165	300	51
200	219.1	FWG-111/4-219	300	51

Product Group: CG01

Grooved Equal Tees - Galvanised

Comparable To
 • Victaulic's No. 002 - sizes 32NB - 200NB

Model Number
 • XGQT07

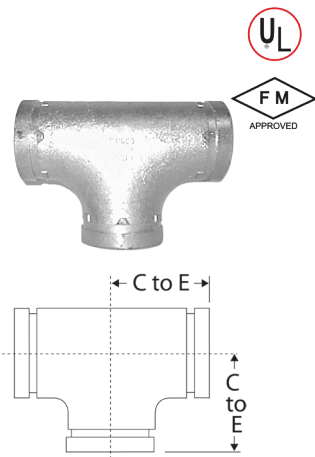

Size (NB)	Pipe OD (mm)	Part Numbers	Working Pressure (PSI)	Centre-to-End (mm)
32	42.4	FWG-20-42S	300	60
40	48.3	FWG-20-48S	300	60
50	60.3	FWG-20-60S	300	70
65	76.1	FWG-20-76S	300	76
80	88.9	FWG-20-88S	300	86
100	114.3	FWG-20-114S	300	102
150	165.1	FWG-20-165S	300	140
150 USA	168.3	FWG-20-168	300	140
200	219.1	FWG-20-219S	300	175
250	273.1	FWG-20-273S	300	215
300	323.9	FWG-20-323S	300	245

Product Group: CG01

Grooved Reducing Tees - Galvanised

Comparable To

- Victaulics's No. 25

Model Number

- XGQT04



Size (NB)	Pipe OD (mm)	Part Numbers	Working Pressure (PSI)	Centre-to-End (mm)
100 x 50	114.3 x 60.3	FWG-TEE-114-60	300	102
100 x 80	114.3 x 88.9	FWG-TEE-114-88	300	102
150 x 50	165.1 x 60.3	FWG-TEE-165-60	300	140
150 x 80	165.1 x 88.9	FWG-TEE-165-88	300	140
150 x 100	165.1 x 114.3	FWG-TEE-165-114	300	140
200 x 100	219.1 x 114.3	FWG-TEE-219-114	300	175
200 x 150	219.1 x 165.1	FWG-TEE-219-165	300	175

Product Group: CG01

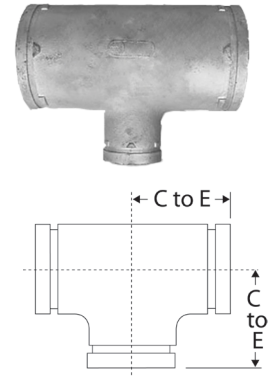

Grooved Tee c/w 25mm BSP Outlet - Galvanised

Comparable To

- Victaulics's No. 29

Model Number

- XGQT04

Size (NB)	Pipe OD (mm)	Part Number	Working Pressure (PSI)	Centre-to-End (mm)
100 x 25	114.3 x 33.7	FWG-TEE-114-34	300	102

Product Group: CG01



Grooved Bullhead Hydrant Tee - Galvanised

Model Number

- FWG-BHT8888114

Size (NB)	Pipe OD (mm)	Part Number	Working Pressure (PSI)	Centre-to-End (mm)
80 x 80 x 100	88.9 x 88.9 x 114.3	FWG-BHT8888114	500	115

Product Group: CG05



Grooved 35° Bullhead Hydrant Tee - Galvanised

Size (NB)	Pipe OD (mm)	Part Number	Working Pressure (PSI)	L (mm)	L2 (mm)
80 x 80 x 100	88.9 x 88.9 x 114.3	FWG-35DT8888114	300	102	115

Product Group: CG05



Grooved Hydrant Stack Tee - Galvanised

Model Number

- FWG-HST-114-88

Size (NB)	Pipe OD (mm)	Part Number	Working Pressure (PSI)	Centre-to-End (mm)
100 x 80	114.3 x 88.9	FWG-HST-114-88	500	83

Product Group: CG05

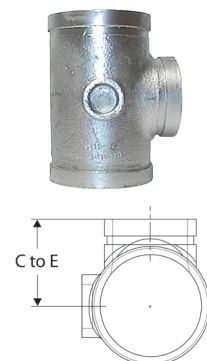

Pipe, Pipe Fittings & Welding

Grooved Reducing Offset Tee - Galvanised

Application

- Ideal for hydrants as only one fitting is required to fit landing valves. A full range of hydrant fabricated fittings are also available. Optional fitting for direct connection of landing valve to provide offset angle. Contact Dixon™ for details.

Comparable To

- Victaulics's No. 30

Model Number

- GT-614



Size (NB)	Pipe OD (mm)	Part Number	Working Pressure (PSI)	Centre-to-End (mm)
100 x 80	114.3 x 88.9	FWG-OST-114-88	500	158.4

Product Group: CG01

Grooved Hydrant Hose Reel Reducing Tee - Galvanised

Application

- Ideal for hydrants as only one fitting is required to fit landing valves and hose reel connections. A full range of hydrant fabricated fittings is also available. Contact Dixon™ for details. Tee fitting for easy connection of landing valve and fire hose reel.

Model Number

- FWGHHRTF1148865

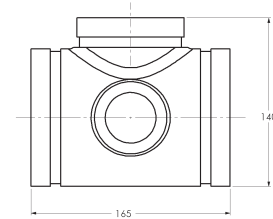
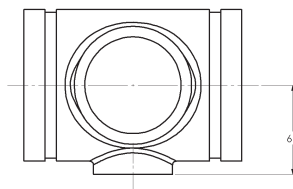

Size (NB)	Pipe OD (mm)	Part Number	Working Pressure (PSI)	Centre-to-End (mm)
100 x 80 x 65 x 25	114.3 x 88.9 x 76.1 x 33.7	FWGHHRTF1148865	500	63/83

Product Group: CG05

Grooved Hydrant/Hose Reel End Run Elbows - Galvanised

Application

- End of run elbowS for connection of either a single hydrant valve or both a single hydrant valve and fire hose reel.

Model Number

- FWG-HERT-114-88/FWGHHRERT1148865



80NB Roll Groove Outlet

25NB BSP Female



80NB Grooved/65NB BSP Female Outlet

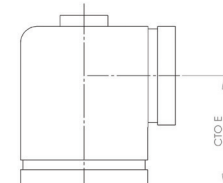
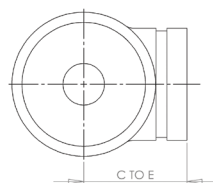

Hydrant End Run Elbow - 80NB Grooved Outlet

Size (NB)	Pipe OD (mm)	Part Numbers	Working Pressure (PSI)	Centre-to-End (mm)
100 x 80	114.3 x 88.9	FWG-HERT-114-88	500	83/165

Product Group: CG05

Hydrant & Hose Reel End Run Elbow - 80NB Grooved/65NB BSP Female Outlet

Size (NB)	Pipe OD (mm)	Part Numbers	Working Pressure (PSI)	Centre-to-End (mm)
100 x 80 x 65 x 25	114.3 x 88.9 x 76.1 x 33.7	FWGHHRERT1148865	500	81/101

Product Group: CG05

Q

Galvanised Roll Grooved Mechanical Tee

Application

- Mechanical tee outlets provide a direct branch connection on a pipe run where sufficient space allows a hole to be cut. The hole is cut slightly oversize to the required branch pipe size to receive an integral locking collar and sealing gasket on the mechanical tee that secures the outlet in position. This fitting can eliminate up to 3 pipe cuts, a tee piece and three couplings.

Hole Cutting

- Before assembly of a mechanical tee outlet, it is necessary to pre-cut a hole in the pipe to the correct size to suit the branch size. See hole diameter in the table below. The hole must be drilled on the pipe centre line. It is important that the pipe surface around the hole and around the pipe circumference under the mechanical tee gasket seating area are free from blemishes, indentations, and burrs likely to adversely affect gasket sealing

Comparable To

- Roll grooved - Style 920
- BSP threaded - Style 927

Model Number

- Roll grooved - XGQT3G
- BSP threaded - XGQT3S

Materials

- Housing - ductile iron to ASTM A536

Approvals

- UL listed, FM approved

Roll Grooved

Size (NB)	Pipe OD (mm)	Part Numbers	Hole Diameter	Working Pressure (PSI)	Centre-to-End (mm)
80 x 50	88.9 x 60.3	FWG-922-88-60-G	64	300	114
100 x 50	114.3 x 60.3	FWG-922-114-60-G	64	300	135
100 x 65	114.3 x 76.1	FWG-922-114-76-G	70	300	135
100 x 80	114.3 x 88.9	FWG-922-114-88-G	89	300	135
150 x 50	165.1 x 60.3	FWG-922-165-60-G	64	300	194
150 x 65	165.1 x 76.1	FWG-922-165-76-G	70	300	194
150 x 80	165.1 x 88.9	FWG-922-165-88-G	89	300	194
150 x 100	165.1 x 114.3	FWG-922-165-114G	114	300	194
200 x 100	219.1 x 114.3	FWG-922-219-114G	114	300	250

Product Group: CG01

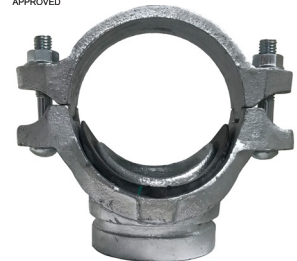

Threaded BSP Female

Size (NB)	Pipe OD (mm)	Part Numbers	Hole Diameter	Working Pressure (PSI)	Centre-to-End (mm)
50 x 20	60.3 x 20	FWG-920-60-27-T	38	300	75
50 x 25	60.3 x 33.7	FWG-922-60-34	48	300	75
50 x 32	60.3 x 42.4	FWG-922-60-43	46	300	75
50 x 40	60.3 x 48.3	FWG-922-60-48	46	300	75
65 x 25	76.1 x 33.7	FWG-920-76-34-T	38	300	93
65 x 32	76.1 x 42.4	FWG-920-76-43-T	46	300	93
65 x 40	76.1 x 48.3	FWG-920-76-48-T	51	300	93
80 x 25	88.9 x 33.7	FWG-920-88-34-T	38	300	114
80 x 32	88.9 x 42.4	FWG-920-88-43-T	46	300	114
80 x 40	88.9 x 48.3	FWG-920-88-48-T	51	300	114
80 x 50	88.9 x 60.3	FWG-920-88-60-T	64	300	114
100 x 25	114.3 x 33.7	FWG-920-114-34T	38	300	135
100 x 32	114.3 x 42.4	FWG-920-114-43T	46	300	135
100 x 40	114.3 x 48.3	FWG-920-114-48T	51	300	135
100 x 50	114.3 x 60.3	FWG-920-114-60T	64	300	135
100 x 65	114.3 x 76.1	FWG-920-114-76T	70	300	135
150 x 25	165.1 x 33.7	FWG-920-165-34T	38	300	187
150 x 32	165.1 x 42.4	FWG-920-165-43T	83	300	187
150 x 40	165.1 x 48.3	FWG-920-165-48T	94	300	187
150 x 50	165.1 x 60.3	FWG-920-165-60T	100	300	187
150 x 65	165.1 x 76.1	FWG-920-165-76T	122	300	187

Product Group: CG01

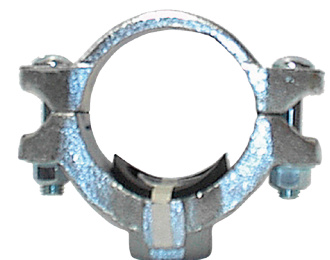

Q

Grooved Concentric Reducers - Galvanised

Comparable To

- Victaulics's No. 50

Model Number

- XGQT07G

Approvals

- UL listed, FM approved



Roll Groove x Roll Groove

Size (NB)	Pipe OD (mm)	Part Numbers	Working Pressure (PSI)	Face-to-Face (mm)
50 x 32	60.3 x 42.4	FWG-50-60-43	300	64
50 x 40	60.3 x 48.3	FWG-50-60-48	300	64
65 x 50	76.1 x 60.3	FWG-50-76-60	300	64
80 x 50	88.9 x 60.3	FWG-50-88-60	300	64
80 x 65	88.9 x 76.1	FWG-50-88-76	300	64
100 x 50	114.3 x 60.3	FWG-50-114-60	300	76
100 x 65	114.3 x 76.1	FWG-50-114-76	300	76
100 x 80	114.3 x 88.9	FWG-50-114-88	300	76
150 x 65	165.1 x 76.1	FWG-50-165-76	300	102
150 x 80	165.1 x 88.9	FWG-50-165-88	300	102
150 x 100	165.1 x 114.3	FWG-50-165-114	300	102
200 x 100	219.1 x 114.3	FWG-50-219-114	300	127
200 x 150	219.1 x 165.1	FWG-50-219-165	300	127

Product Group: CG01

Grooved Concentric Reducers x Female BSP - Galvanised

Comparable To

- Victaulics's No. 52

Model Number

- XGQT07G

Approvals

- UL listed, FM approved



Size (NB)	Pipe OD (mm)	Part Numbers	Working Pressure (PSI)	Face-to-Face (mm)
50 x 25	60.3 x 33.7	FWG-50-60-34-F	300	64
65 x 25	76.1 x 33.7	FWG-50-76-34-F	300	64
100 x 65	114.3 x 76.1	FWG-50-114-76-F	300	76
150 x 65	165.1 x 76.1	FWG-50-165-76-F	300	102

Product Group: CG01

Grooved Eccentric Reducers - Galvanised

Comparable To

- Victaulics's No. 51

Model Number

- XGQT07P

Approvals

- UL listed, FM approved

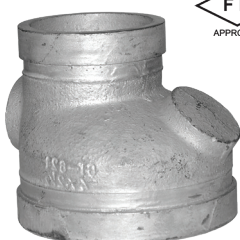

Size (NB)	Pipe OD (mm)	Part Numbers	Working Pressure (PSI)	Face-to-Face (mm)
100 x 65	114.3 x 76.1	FWG-51-114-76	300	76
100 x 80	114.3 x 88.9	FWG-51-114-88	300	76
150 x 80	165.1 x 88.9	FWG-51-165-88	300	102
150 x 100	165.1 x 114.3	FWG-51-165-114	300	102

Product Group: CG01

Grooved Screwed Adaptors - Galvanised

Model Number

- XGQT07G

Size Male BSP x RG (NB)	Pipe OD (mm)	Part Numbers	Working Pressure (PSI)
25 x 25	33.7	FWG-SA-25-25BSP	500
32 x 32	42.4	FWG-SA-32-32BSP	500
40 x 40	48.3	FWG-SA-40-40BSP	500
50 x 40	60.3 x 48.3	FWG-SA-50-40BSP	500
50 x 50	60.3	FWG-SA-50-50BSP	500
65 x 65	76.1	FWG-SA-65-65BSP	500
80 x 80	88.9	FWG-SA-80-80BSP	500
100 x 100	114.3	FWG-SA-100100BSP	500
100 x 125	114.3 x 139.7	FWG-SA-100125BSP	500
150 x 125	165.1 x 139.7	FWG-SA-150125BSP	500
150 x 150	165.1	FWG-SA-150150BSP	500

Product Group: CG01

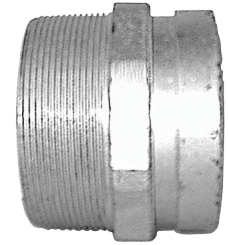

Grooved End Cap - Galvanised

Comparable To

- Victaulics's No. 6

Model Number

- XGQT06

Approvals

- UL listed, FM approved

Size (NB)	Pipe OD (mm)	Part Numbers	Working Pressure (PSI)
32	42.4	FWG-60-42	300
40	48.3	FWG-60-48	300
50	60.3	FWG-60-60	300
65	76.1	FWG-60-76	300
80	88.9	FWG-60-88	300
100	114.3	FWG-60-114	300
150	165.1	FWG-60-165	300
200	219.1	FWG-60-219	300

Product Group: CG01



Grooved End Cap c/w BSP Outlet - Galvanised

Model Number

- XGQT06S

Size (NB) x BSP Outlet	Pipe OD (mm)	Part Numbers	Working Pressure (PSI)
80 x 25	88.9	FWG-60-88T	300
100 x 25	114.3	FWG-60-114T	300
150 x 25	165.1	FWG-60-165T	300
200 x 50	219.1	FWG-60-219T	300

Product Group: CG01



Grooved x Flange Adaptors - Glavanised

Material

- Ductile iron to ASTM A536

Model Number

- 321G

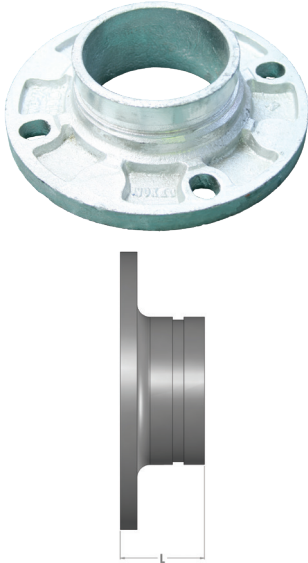

Size (NB)	Pipe OD (mm)	Part Numbers	Flange Pattern	Face-to-Face (mm)
50	60.3	FWG-FA-60DE	Table D/E	65
65	76.1	FWG-FA-76DE	Table D/E	70
80	88.9	FWG-FA-88DE	Table D/E	60
100	114.3	FWG-FA-114D	Table D	60
100	114.3	FWG-FA-114E	Table E	60
150	165.1	FWG-FA-165E	Table E	65
200	219.1	FWG-FA-219E	Table E	85
250	273.1	FWG-FA-250E	Table E	85
300	323.9	FWG-FA-323E	Table E	100

Refer to section X - General Technical Information for flange dimensions

Product Group: CG01

Grooved x Copper Brazing Adaptors

Application

- Designed to braze directly to copper tube, adapting to the roll grooved system.

Material

- Brass



Size (NB)	To Suit Tube x Roll Groove		Part Numbers
	Copper Tube OD (mm)	Roll Groove Pipe OD (mm)	
50	50.8	60.3	FFS-BA50CU60RG
65	63.5	76.1	FFS-BA63CU76RG
80	76.2	88.9	FFS-BA80CU88RG
100	101.6	114.3	FFS-BA100CU114RG
150	152.4	165.1	FFS-BA150CU165RG
200	203.2	219.1	FFS-BA200CU219RG

Product Group: FP01

PetroGard™ Protective Coatings



Application

- To prevent the formation of voids and pockets when wrapping, it is recommended to use PetroGard™ Mastic for shaping complex surfaces like valves and flanges.

Design

- PCS Petrogard™ system were developed for the protection of metal surfaces in the most severe environments. They are designed to be applied over wire brushed surfaces in exposed, underground, and underwater applications

Surface Preparation

- Remove all contaminants such as dirt, oil, scale, and excessive moisture. Remove all loose rust, paint, and other residue by hand or power tool in accordance with AS1627-1977 or AS1627, part 2 - 1975. All surfaces should be coated with petro primer paste to fill any hollow or surface irregularity and to ensure good contact with the tape

Installation

- PetroGard™ - should be spirally wrapped using a 15mm overlap. However, for buried applications, 55% should be used to ensure a double layer. When a pipe is vertical, wrapping should begin at the bottom. When applying the tape, all overlaps should be smoothed by hand. A 50mm roll to roll overlap should be used when starting a new roll
- PetroGard™ Overwrap - where mechanical protection is required, PetroGard™ Overwrap should be employed using a 15mm overlap. In severe underground conditions, a 55% overwrap should be considered. Consult Dixon™ for details and recommendations

PetroGard™ Tape Standard

Tape Width (mm)	Length (mtr)	Part Numbers
50	10	FPT-PT-050
75	10	FPT-PT-075
100	10	FPT-PT-100
150	10	FPT-PT-150

Product Group: AE06



PetroGard™ Overwrap Tape

Tape Width (mm)	Length (mtr)	Part Numbers
50	30	FPT-PO-050
100	30	FPT-PO-100
150	30	FPT-PO-150

Product Group: AE06



PetroGard™ Primer Paste

Part Numbers	Size
FPT-PP-4	2.5kg Tub

Product Group: AE06



PetroGard™ Mastic

Part Numbers	Size
FPT-PM-3	3kg Block

Product Group: AE06



Q

Bolted Couplings - Shouldered

Application

- For joining of shouldered end pipe in mining and construction industries.

Materials

- Housing: SG Iron to AS 1831 400-250-12
- Nuts & bolts
 - metric grade 8.8 for sizes 50NB to 300NB
 - metric grade 4.6 for sizes 350NB to 600NB
- Gasket: Nitrile Buna
- Finish: Zinc plated

Standards

- Working pressure (capacity) as tested to AWWA C606 requirements. Safety factor of 3:1

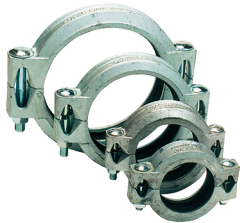

08/048/20/020
3-Segment Coupling

Size (NB)	Pipe OD (mm)	Part Numbers	Working Pressure (PSI)	Housing Segments Per Coupling
50	60.2	FSHG-COUP-50	754	2
80	88.9	08/048/20/002 ¹	754	2
100	114.3	FSHG-COUP-100	754	2
150	165.1	08/048/20/005 ¹	580	2
150.3 USA	168.3	08/048/20/168	580	2
200	219.1	FSHG-COUP-200	580	2
250	273.9	08/048/20/007	261	2
300	323.9	08/048/20/008	261	2
350	355.6	08/048/20/020	TBA	3
400	406.4	08/048/20/021	TBA	3
450	457.0	08/048/20/022	TBA	4
600	609.6	08/048/20/024	TBA	4

¹ Minsup branded

Product Group: AE01

Quick Release Shouldered Couplings

Application

- Quick release couplings offer substantial cost savings in reducing downtime and facilitating fast assembly and disassembly of temporary pipelines.

Design

- No nut and bolts to be lost, or threads to be damaged
- No tools are required
- Improved lever and hinge design significantly reduce opening and closing efforts
- Internal mating tongue and groove feature prevents seal pinching during the closure

Materials

- Housing/Lever/Side Plates: SG Iron - ISO 1083, 1987:400 250-15 SGI
- Side Plates (50NB, 80NB 200NB): Pressed mild steel
- Gasket: Nitrile Buna
- Finish: Zinc plated

Standards

- Working pressure (capacity) as tested to AWWA C606 requirements. Safety factor of 2:1



Size (NB)	Pipe OD (mm)	Part Numbers	Working Pressure (PSI)
50	60.2	08/048/19/000G	348
80	88.9	08/048/19/002G	348
100	114.3	08/048/19/003G	348
150	165.1	08/048/19/005G	348
200	219.1	08/048/19/006G	348

Product Group: AE01

Quick Release Shouldered Couplings - Stainless Steel



Design

- Made to fit standard pipe as per the ductile clamps. Seals are standards Minsup® range

Material

- Cast components: CF8M
- Machined components: 316SS
- Locking pin: Zinc plated carbon steel
- Gasket: Nitrile Buna rubber

Size (NB)	Pipe OD (mm)	Part Numbers	Working Pressure (PSI)
50	60.3	08/048/19/000SS	300
100	114.3	08/048/19/003SS	300
150	165.1	08/048/19/005S	200
150 USA	168.3	08/048/19/168SS	200

Product Group: AE01



Shouldered Coupling Gasket

Nitrile Buna

Size (NB)	Pipe OD (mm)	Part Numbers
50	60.2	05/048/22/000
80	88.9	05/048/22/002
100	114.3	05/048/22/003
150	165.1	05/048/22/005
150 USA	168.3	05/048/22/168
200	219.1	05/048/22/006
250	273.9	05/048/22/007
300	323.9	05/048/22/008
350	355.6	05/048/22/009
400	406.4	05/048/22/020
450	457.0	05/048/22/021
500	508.0	05/048/22/022
600	609.6	05/048/22/024

Product Group: AE01



Q



- Couplings are not recommended for use with air

90° Shouldered Elbows



Application

- For use with shouldered end pipe and coupling in mining and construction industries.

Features

- Galvanised for corrosion protection - long series

Materials

- Mild steel galvanised to AS 4792:2066

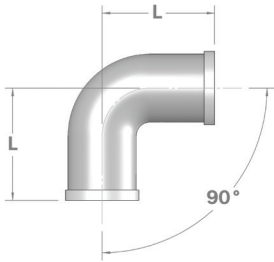

Size (NB)	Pipe OD (mm)	Part Numbers	Working Pressure (PSI)	L (mm)
50	60.2	08/048/01/000T	750	152
80	88.9	08/048/01/002T	750	203
100	114.3	08/048/01/003T	750	229
150	165.1	08/048/01/005T	580	273
200	219.1	08/048/01/006T	580	305

Product Group: AE02

45° Shouldered Elbows

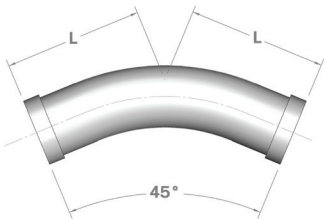

Size (NB)	Pipe OD (mm)	Part Numbers	Working Pressure (PSI)	L (mm)
50	60.2	08/048/02/000T	750	78
80	88.9	08/048/02/002T	750	109
100	114.3	08/048/02/003T	750	135
150	165.1	08/048/02/005T	580	173
200	219.1	08/048/02/006T	580	235

Product Group: AE02

90° Shouldered Bends

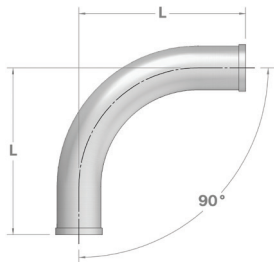

Size (NB)	Pipe OD (mm)	Part Numbers	Working Pressure (PSI)	L (mm)
50	60.2	08/048/31/000	750	222
80	88.9	08/048/31/002	750	305
100	114.3	08/048/31/003	750	425
150	165.1	08/048/31/005	580	610
200	219.1	08/048/31/006	580	-

Product Group: AE02

45° Shouldered Bends

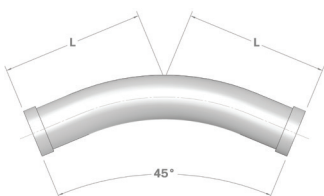

Size (NB)	Pipe OD (mm)	Part Numbers	Working Pressure (PSI)	L (mm)
50	60.2	08/048/34/000T	750	187
80	88.9	08/048/34/002T	750	260
100	114.3	08/048/34/003T	750	365
150	165.1	08/048/34/005T	580	521
200	219.1	08/048/34/006T	580	778

Product Group: AE02

Shouldered Setting Pieces

Size (NB)	Pipe OD (mm)	Part Numbers	Working Pressure (PSI)	L (mm)
50	60.2	08/048/16/000	750	76.2
80	88.9	08/048/16/002	750	76.2
100	114.3	08/048/16/003	750	88.9
150	165.1	08/048/16/005	580	101.6
200	219.1	08/048/16/006	580	-

Product Group: AE02

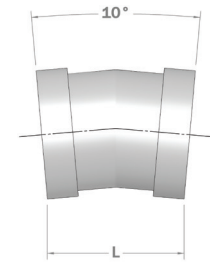

Shouldered Equal Tees

Size (NB)	Pipe OD (mm)	Part Numbers	Working Pressure (PSI)	L (mm)	L2 (mm)
50	60.2	08/048/05/000T	750	304	152
80	88.9	08/048/05/002T	750	406	203
100	114.3	08/048/05/003T	750	458	229
150	165.1	08/048/05/005T	580	508	254
200	219.1	08/048/05/006T	580	610	305

Product Group: AE02

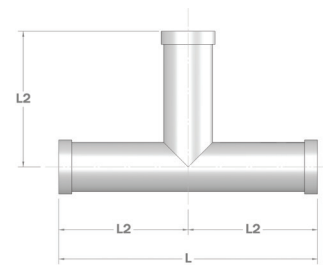

Shouldered Offset Equal Tee

Size (NB)	Pipe OD (mm)	Part Numbers	Working Pressure (PSI)	L (mm)	L2 (mm)
50	60.2	08/048/09/000T	750	304	215
80	88.9	08/048/09/002T	750	406	275
100	114.3	08/048/09/003T	750	458	299
150	165.1	08/048/09/005T	580	508	394
200	219.1	08/048/09/006T	580	400	200

Product Group: AE02

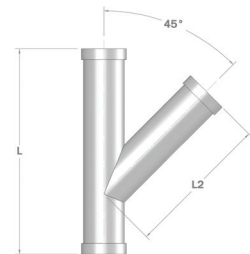

Shouldered Flanged Adaptors

Size (NB)	Pipe OD (mm)	Part Numbers	Working Pressure (PSI)	Flange	Length (mm)
50	60.2	08/048/11/000T	750	Table D/E	100
80	88.9	08/048/11/042	750	Table E	100
100	114.3	08/048/11/043	750	Table E	100
		08/048/11/043T	750	Table D	470
150	165.1	08/048/11/045	580	Table E	100
200	219.1	08/048/11/046T	580	Table D	605

Product Group: AE02

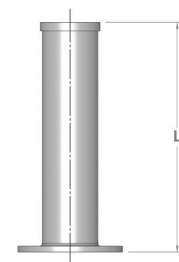

Q

Shouldered x BSPT Male Threaded Adaptors



08/048/10/003

Size (NB)	Pipe OD (mm)	BSP (mm)	Part Numbers	Working Pressure (PSI)	Length (mm)
50	60.2	50	08/048/10/000 ¹	750	150
			08/048/10/000T	750	318
80	88.9	80	08/048/10/002	750	150
100	114.3	100	08/048/10/003 ¹	750	75
			08/048/10/003T	750	470
150	165.1	150	08/048/10/005	580	150

¹Are a one piece casting design, plated SG iron.

Product Group: AE02

Reducing Shouldered Adaptors x BSP



08/048/13/011

Size (NB)	Pipe OD (mm)	BSP (mm)	Part Numbers	Working Pressure (PSI)	Length (mm)
100	114.3	50	08/048/13/002	750	279
100	114.3	80	08/048/13/011	750	110
150	165.1	100	08/048/13/016	580	355

Product Group: AE02

Q

DIXON
SHOULDERED
COUPLING

Designed for use in both underground and surface **mining applications**



Shouldered Concentric Reducers

Size (NB)	Pipe OD (mm)	Part Numbers	Working Pressure (PSI)	L (mm)
80 x 50	88.9 x 60.2	08/048/14/001T	750	203
100 x 50	114.3 x 60.2	08/048/14/002T	750	110
150 x 50	165.1 x 60.2	08/048/14/004T	580	305
150 x 80	165.1 x 88.9	08/048/14/013T	580	305
150 x 100	165.1 x 114.3	08/048/14/016T	580	305

Product Group: AE02

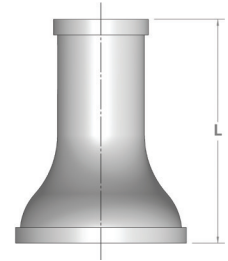

Shouldered Concentric Reducers

Size (NB)	Pipe OD (mm)	Part Numbers	Working Pressure (PSI)	L (mm)
100 x 80	114.3 x 88.9	08/048/14/011T	750	110

Product Group: AE02



Shouldered Y-Pieces

Size (NB)	Pipe OD (mm)	Part Numbers	Working Pressure (PSI)	L (mm)	L2 (mm)
50	60.2	08/48/32/000T	750	165	89
80	88.9	08/48/32/002T	750	229	127
100	114.3	08/48/32/003T	750	279	127
150	165.1	08/48/32/005T	580	330	152

Product Group: AE02

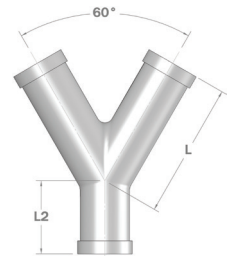

Shouldered Reducing Tees

Size (NB)	Pipe OD (mm)	Part Numbers	Working Pressure (PSI)	L (mm)	L2 (mm)
50 x 80	60.2 x 88.9	08/048/08/001	750	406	203
100 x 50	114.3 x 60.2	08/048/08/003	750	458	229
150 x 50	165.1 x 60.2	08/048/08/010	580	508	254

Product Group: AE02

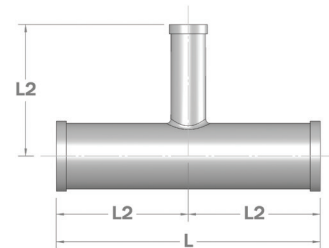

Reducing Tee Shouldered x BSP Male

Size (NB)	Pipe OD (mm)	BSP (mm)	Part Numbers	Working Pressure (PSI)	L (mm)	L2 (mm)
50	60.2	25	08/048/07/000	750	304	152
100	114.3	50	08/048/07/008	750	458	229

Product Group: AE02

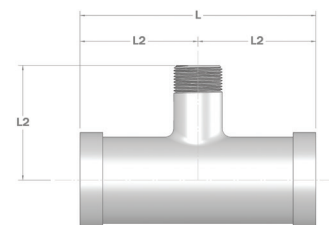

Q

Shouldered Blank Ends

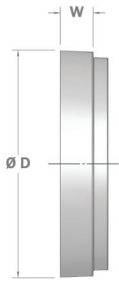

Size (NB)	Pipe OD (mm)	Part Numbers	Working Pressure (PSI)	OD (mm)	W (mm)
50	60.2	08/048/03/000	750	66.5	16.0
80	88.9	08/048/03/002	750	97.0	16.0
100	114.3	08/048/03/003	580	122.0	17.5
150	165.1	08/048/03/005	750	174.5	17.5
200	219.1	08/048/03/006	580	232.0	20.5

Product Group: AE01

Shouldered Blank Ends with Female BSP Outlet

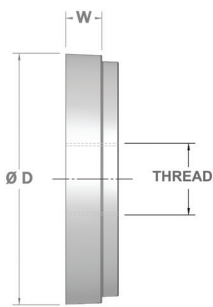

Size (NB)	Pipe OD (mm)	Part Numbers	Thread BSP (mm)	Working Pressure (PSI)	OD (mm)	W (mm)
50	60.2	08/048/04/000	25	750	66.5	16.0
80	88.9	08/048/04/003	25	750	97.0	16.0
		08/048/04/004	50	750	97.0	16.0
100	114.3	08/048/04/006	25	750	122.0	17.5
		08/048/04/007	50	750	122.0	17.5
		08/048/04/009	80	750	122.0	17.5
150	165.1	08/048/04/015	25	580	174.5	17.5
		08/048/04/016	50	580	174.5	17.5
		08/048/04/018	80	580	174.5	17.5

Product Group: AE01

Shoulder Rings

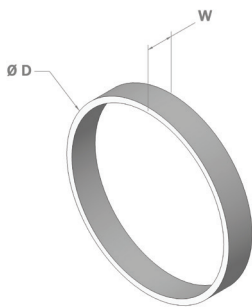

Size (NB)	Pipe OD (mm)	Part Numbers	OD (mm)	W (mm)
50	60.2	08/048/18/000	66.5	16.0
80	88.9	08/048/18/002	97.0	16.0
100	114.3	08/048/18/003	122.0	17.5
150	165.1	08/048/18/005	174.5	17.5
150 USA	168.3	08/048/18/658	178.0	17.5
200	219.1	08/048/18/006	232.0	20.5

Product Group: AE02

Split Ring

Size (NB)	Pipe OD (mm)	Part Numbers	OD (mm)	W (mm)
250	273.1	08/048/18/007	286.0	20.5
300	323.9	08/048/18/008	336.5	20.5
350	355.6	08/048/18/009	368.5	24.0
400	406.4	08/048/18/010	419.0	25.5
450	457.0	08/048/18/021	470.0	25.5
500	508.0	08/048/18/023	520.5	25.5
600	610.0	08/048/18/024	622.5	25.5

Product Group: AE02

Rubber Flange Gaskets AS2129

Size (NB)	Pipe OD (mm)	Part Numbers	
		Table D	Table E
25	33.4	-	GAS-FF-25E
32	42.4	-	GAS-FF-32E
40	48.3	-	GAS-FF-40E
50	60.2	-	GAS-FF-50E
65	88.9	-	GAS-FF-65E
80	88.9	-	GAS-FF-80E
100	114.3	GAS-FF-100D	GAS-FF-100E
125	165.1	-	GAS-FF-125E
150	165.1	GAS-FF-150D	GAS-FF-150E
200	219.1	GAS-FF-200D	GAS-FF-200E
250	273.9	-	GAS-FF-250E
300	323.9	-	GAS-FF-300E

Product Group: GA01

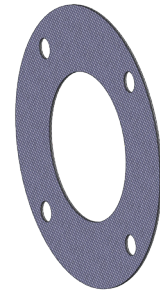

Non Asbestos Flange Gaskets (full face) AS2129

Application

- Air, water, gas and some chemicals. Contact Dixon™ for specific data.

Design

- An all-purpose flange gasket manufactured from aramid fibres bound with nitrile butadiene rubber (NBR)

Temperature Rating

- Maximum 400°C

Pressure Rating

- Working pressure 1600 PSI (16 Bar)

Standards

- Complies with ASTM F712230-M5 and DIN3535 parts 4 & 5

Size (NB)	Pipe OD (mm)	Part Numbers		
		Table E	Table H	Table D
50	60.2	GAS-NA-FF-50E	-	-
80	88.9	GAS-NA-FF-80E	-	-
100	114.3	GAS-NA-FF-100E	-	GAS-NA-FF-100D
150	165.1	GAS-NA-FF-150E	GAS-NA-FF-150H	-
200	219.1	GAS-NA-FF-200E	-	-

Product Group: GA01

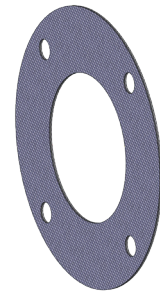

Neoprene Flange Gaskets (full face) AS2129

Application

- Fire-proof hydraulic liquids, lubricating oils, fuel oils, hydraulic oils, petrol (ULP), kerosene, water (under 80°C), alcohols, diluted acids, alkalies, gases, vegetable oils, animal fats, and aliphatic hydrocarbons.

Design

- Black neoprene 3.2mm thick, flame, ozone, and sunlight resistant

Size (NB)	Pipe OD (mm)	Part Number
		Table E
50	60.2	GAS-NEO-FF-50E

Product Group: GA01

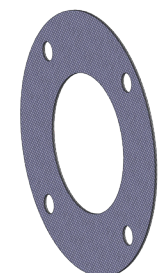

Q

Pipe, Pipe Fittings & Welding

BSP Threaded Pipe Fittings

Malleable Iron

Application

- General low pressure air and water.

Body Material

- ISO 5922 Malleable Cast Iron

Design Standards

- Generally in accordance with AS3673. Slight variations may occur where manufacturer's dimensions are used

Thread Standard

- ISO 7-1 - Pipe threads where pressure-tight joints are made on the threads

Plating Standard

- ISO 1461 - Hot dip galvanised coatings on fabricated iron and steel articles

Working Pressure

- 150 PSI

Stainless Steel

Application

- For use in low-pressure applications, suitable for use in harsh environments such as chemical applications, corrosive environments as well as standard air and water applications.

Body Material

- CF8M (316) manufactured to ASTM A35n

Design Standards

- Generally in accordance with AS3673. Slight variations may occur where manufacturer's dimensions are used

Thread Standard

- ISO 7-1 pipe threads where pressure-tight joints are made on the threads

Design Standard

- Class 150lbs

Working Pressure

- 300 PSI



Malleable Iron



Stainless Steel

90° Elbows - Female x Female

Thread Size BSP		Part Numbers	
mm	inch	Malleable Iron	316 Stainless Steel
6	1/8	-	SS16EL006
8	1/4	FMG-EFF-8	SS16EL008
10	3/8	FMG-EFF-10	SS16EL010
15	1/2	FMG-EFF-15	SS16EL015
20	3/4	FMG-EFF-20	SS16EL020
25	1	FMG-EFF-25	SS16EL025
32	1 1/4	FMG-EFF-32	SS16EL032
40	1 1/2	FMG-EFF-40	SS16EL040
50	2	FMG-EFF-50	SS16EL050
65	2 1/2	FMG-EFF-65	SS16EL065
80	3	FMG-EFF-80	SS16EL080
100	4	FMG-EFF-100	SS16EL100

Product Group: GM01

Product Group: AW01

90° Elbows - Male x Female

Thread Size BSP		Part Numbers	
mm	inch	Malleable Iron	316 Stainless Steel
6	1/8	-	SS16ELMF006
8	1/4	FMG-EMF-8	SS16ELMF008
10	3/8	FMG-EMF-10	SS16ELMF010
15	1/2	FMG-EMF-15	SS16ELMF015
20	3/4	FMG-EMF-20	SS16ELMF020
25	1	FMG-EMF-25	SS16ELMF025
32	1 1/4	FMG-EMF-32	SS16ELMF032
40	1 1/2	FMG-EMF-40	SS16ELMF040
50	2	FMG-EMF-50	SS16ELMF050
65	2 1/2	FMG-EMF-65	SS16ELMF065
80	3	FMG-EMF-80	SS16ELMF080
100	4	FMG-EMF-100	SS16ELMF100

Product Group: GM01

Product Group: AW01



Malleable Iron



Stainless Steel

90° Reducing Elbows - Female x Female

Thread Size BSP		Part Numbers
mm	inch	Malleable Iron
20 x 15	¾ x ½	FMG-EFF-20-15
25 x 10	1 x ¾	FMG-EFF-25-10
25 x 15	1 x ½	FMG-EFF-25-15
25 x 20	1 x ¾	FMG-EFF-25-20
32 x 10	1¼ x ¾	FMG-EFF-32-10
32 x 15	1¼ x ½	FMG-EFF-32-15
32 x 20	1¼ x ¾	FMG-EFF-32-20
32 x 25	1¼ x 1	FMG-EFF-32-25
40 x 15	1½ x ½	FMG-EFF-40-15
40 x 20	1½ x ¾	FMG-EFF-40-20
40 x 25	1½ x 1	FMG-EFF-40-25
40 x 32	1½ x 1¼	FMG-EFF-40-32
50 x 15	2 x ½	FMG-EFF-50-15
50 x 20	2 x ¾	FMG-EFF-50-20
50 x 25	2 x 1	FMG-EFF-50-25
50 x 32	2 x 1¼	FMG-EFF-50-32
50 x 40	2 x 1½	FMG-EFF-50-40

Product Group: GM01



90° Bends

Thread Size BSP		Part Numbers	
mm	inch	Malleable Iron	
		Male x Female	Female x Female
15	½	FMG-BMF-15	FMG-BFF-15
20	¾	FMG-BMF-20	FMG-BFF-20
25	1	FMG-BMF-25	FMG-BFF-25
32	1¼	FMG-BMF-32	FMG-BFF-32
40	1½	FMG-BMF-40	FMG-BFF-40
50	2	FMG-BMF-50	FMG-BFF-50
65	2½	FMG-BMF-65	FMG-BFF-65
80	3	FMG-BMF-80	FMG-BFF-80
100	4	FMG-BMF-100	FMG-BFF-100

Product Group: GM01



Male by Female



Female by Female

45° Elbows - Female x Female

Thread Size BSP		Part Numbers	
mm	inch	Malleable Iron	316 Stainless Steel
15	15	FMG-EFF45-15	-
20	¾	FMG-EFF45-20	-
25	1	FMG-EFF45-25	-
32	1¼	FMG-EFF45-32	-
40	1½	FMG-EFF45-40	-
50	2	FMG-EFF45-50	-
65	2½	FMG-EFF45-65	-
80	3	FMG-EFF45-80	SS16E45FF080
100	4	FMG-EFF45-100	-

Product Group: @W01



Malleable Iron

Q



Malleable Iron

45° Elbows - Male x Female

Thread Size BSP		Part Numbers	
mm	inch	Malleable Iron	316 Stainless Steel
15	½	FMG-EMF45-15	-
20	¾	FMG-EMF45-20	-
25	1	FMG-EMF45-25	SS16E45MF025
32	1¼	FMG-EMF45-32	SS16E45MF032
40	1½	FMG-EMF45-40	SS16E45MF040
50	2	FMG-EMF45-50	SS16E45MF050

Product Group: GM01

Product Group: AW01



Stainless Steel

16.6° Elbow - Male x Female

Thread Size BSP		Part Numbers
mm	inch	316 Stainless Steel
25	1	SS16E16MF025
40	1½	SS16E16MF040
50	2	SS16E16MF050
65	2½	SS16E16MF065

Product Group: AW01



Malleable Iron



Stainless Steel

Equal Tees - Female

Thread Size BSP		Part Numbers	
mm	inch	Malleable Iron	316 Stainless Steel
6	¼	-	SS16T006
8	¼	FMG-TEE-8	SS16T008
10	⅜	FMG-TEE-10	SS16T010
15	½	FMG-TEE-15	SS16T015
20	¾	FMG-TEE-20	SS16T020
25	1	FMG-TEE-25	SS16T025
32	1¼	FMG-TEE-32	SS16T032
40	1½	FMG-TEE-40	SS16T040
50	2	FMG-TEE-50	SS16T050
65	2½	FMG-TEE-65	SS16T065
80	3	FMG-TEE-80	SS16T080
100	4	FMG-TEE-100	SS16T0100

Product Group: GM01

Product Group: AW01

Reducing Tees - Female

Thread Size BSP		Part Numbers
mm	inch	Malleable Iron
15 x 10	½ x ⅜	FMG-TEE-15-10
20 x 10	¾ x ⅜	FMG-TEE-20-10
20 x 15	¾ x ½	FMG-TEE-20-15
25 x 10	1 x ⅜	FMG-TEE-25-10
25 x 15	1 x ½	FMG-TEE-25-15
25 x 20	1 x ¾	FMG-TEE-25-20
32 x 15	1¼ x ½	FMG-TEE-32-15
32 x 20	1¼ x ¾	FMG-TEE-32-20
32 x 25	1¼ x 1	FMG-TEE-32-25
40 x 15	1½ x ½	FMG-TEE-40-15
40 x 20	1½ x ¾	FMG-TEE-40-20
40 x 25	1½ x 1	FMG-TEE-40-25
40 x 32	1½ x 1¼	FMG-TEE-40-32
50 x 15	2 x ½	FMG-TEE-50-15
50 x 20	2 x ¾	FMG-TEE-50-20
50 x 25	2 x 1	FMG-TEE-50-25
50 x 32	2 x 1¼	FMG-TEE-50-32
50 x 40	2 x 1½	FMG-TEE-50-40
65 x 25	2½ x 1	FMG-TEE-65-25
65 x 32	2½ x 1¼	FMG-TEE-65-32
65 x 40	2½ x 1½	FMG-TEE-65-40
80 x 40	3 x 1½	FMG-TEE-80-40
80 x 50	3 x 2	FMG-TEE-80-50
100 x 65	4 x 2½	FMG-TEE-100-65

Product Group: GM01



Hex Nipples

Thread Size BSP		Part Numbers	
mm	inch	Malleable Iron	316 Stainless Steel
6	¼	-	SS16HN006
8	¼	FMG-HN-8	SS16HN008
10	⅜	FMG-HN-10	SS16HN010
15	½	FMG-HN-15	SS16HN015
20	¾	FMG-HN-20	SS16HN020
25	1	FMG-HN-25	SS16HN025
32	1¼	FMG-HN-32	SS16HN032
40	1½	FMG-HN-40	SS16HN040
50	2	FMG-HN-50	SS16HN050
65	2½	FMG-HN-65	SS16HN065
80	3	FMG-HN-80	SS16HN080
100	4	FMG-HN-100	SS16HN100

Product Group: GM01

Product Group: AW01



Malleable Iron



Stainless Steel

Q

Reducing Hex Nipples



Malleable Iron



Stainless Steel

Thread Size BSP		Part Numbers	
mm	inch	Malleable Iron	316 Stainless Steel
8 x 6	¼ x ⅛	FMG-HN-8-6	SS16N00806
10 x 6	⅜ x ⅛	FMG-HN-10-6	SS16N01006
10 x 8	⅜ x ¼	FMG-HN-10-8	SS16N01008
15 x 6	½ x ⅛	FMG-HN-15-6	-
15 x 8	½ x ¼	FMG-HN-15-8	SS16N01508
15 x 10	½ x ⅜	FMG-HN-15-10	SS16N01510
20 x 8	¾ x ¼	FMG-HN-20-8	SS16N02008
20 x 10	¾ x ⅜	FMG-HN-20-10	SS16N02010
20 x 15	¾ x ½	FMG-HN-20-15	SS16N02015
25 x 15	1 x ½	FMG-HN-25-15	SS16N02515
25 x 20	1 x ¾	FMG-HN-25-20	SS16N02520
32 x 15	1 ¼ x ½	FMG-HN-32-15	-
32 x 20	1 ¼ x ¾	FMG-HN-32-20	SS16N03220
32 x 25	1 ¼ x 1	FMG-HN-32-25	SS16N03225
40 x 15	1 ½ x ½	FMG-HN-40-15	-
40 x 20	1 ½ x ¾	FMG-HN-40-20	SS16N04020
40 x 25	1 ½ x 1	FMG-HN-40-25	SS16N04025
40 x 32	1 ½ x 1 ¼	FMG-HN-40-32	SS16N04032
50 x 25	2 x 1	FMG-HN-50-25	SS16N05025
50 x 32	2 x 1 ¼	FMG-HN-50-32	SS16N05032
50 x 40	2 x 1 ½	FMG-HN-50-40	SS16N05040
65 x 50	2 ½ x 2	FMG-HN-65-50	SS16N06550
80 x 50	3 x 2	FMG-HN-80-50	SS16N08050
80 x 65	3 x 2 ½	FMG-HN-80-65	SS16N08065
100 x 50	4 x 2	FMG-HN-100-50	SS16N10050
100 x 65	4 x 2 ½	FMG-HN-100-65	-
100 x 80	4 x 3	FMG-HN-100-80	SS16N10080

Product Group: GM01

Product Group: AW01

Sockets



Malleable Iron

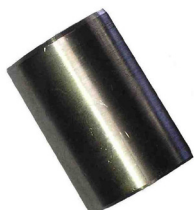

Stainless Steel

Thread Size BSP		Part Numbers	
mm	inch	Malleable Iron	316 Stainless Steel
6	⅛	-	SS16S006
8	¼	FMG-SOC-8	SS16S008
10	⅜	FMG-SOC-10	SS16S010
15	½	FMG-SOC-15	SS16S015
20	¾	FMG-SOC-20	SS16S020
25	1	FMG-SOC-25	SS16S025
32	1 ¼	FMG-SOC-32	SS16S032
40	1 ½	FMG-SOC-40	SS16S040
50	2	FMG-SOC-50	SS16S050
65	2 ½	FMG-SOC-65	SS16S065
80	3	FMG-SOC-80	SS16S080
100	4	FMG-SOC-100	SS16S0100

Product Group: GM01

Product Group: AW01

Reducing Socket

Thread Size BSP		Part Numbers
mm	inch	Malleable Iron
10 x 6	$\frac{3}{8} \times \frac{1}{8}$	FMG-SOC-10-6
10 x 8w	$\frac{3}{8} \times \frac{1}{4}$	FMG-SOC-10-8
15 x 6	$\frac{1}{2} \times \frac{1}{8}$	FMG-SOC-15-6
15 x 8	$\frac{1}{2} \times \frac{1}{4}$	FMG-SOC-15-8
15 x 10	$\frac{1}{2} \times \frac{3}{8}$	FMG-SOC-15-10
20 x 10	$\frac{3}{4} \times \frac{3}{8}$	FMG-SOC-20-10
20 x 15	$\frac{3}{4} \times \frac{1}{2}$	FMG-SOC-20-15
25 x 10	$1 \times \frac{3}{8}$	FMG-SOC-25-10
25 x 15	$1 \times \frac{1}{2}$	FMG-SOC-25-15
25 x 20	$1 \times \frac{3}{4}$	FMG-SOC-25-20
32 x 10	$1\frac{1}{4} \times \frac{3}{8}$	FMG-SOC-32-10
32 x 15	$1\frac{1}{4} \times \frac{1}{2}$	FMG-SOC-32-15
32 x 20	$1\frac{1}{4} \times \frac{3}{4}$	FMG-SOC-32-20
32 x 25	$1\frac{1}{4} \times 1$	FMG-SOC-32-25
40 x 15	$1\frac{1}{2} \times \frac{1}{2}$	FMG-SOC-40-15
40 x 20	$1\frac{1}{2} \times \frac{3}{4}$	FMG-SOC-40-20
40 x 25	$1\frac{1}{2} \times 1$	FMG-SOC-40-25
40 x 32	$1\frac{1}{2} \times 1\frac{1}{4}$	FMG-SOC-40-32
50 x 10	$2 \times \frac{3}{8}$	FMG-SOC-50-10
50 x 15	$2 \times \frac{1}{2}$	FMG-SOC-50-15
50 x 20	$2 \times \frac{3}{4}$	FMG-SOC-50-20
50 x 25	2×1	FMG-SOC-50-25
50 x 32	$2 \times 1\frac{1}{4}$	FMG-SOC-50-32
50 x 40	$2 \times 1\frac{1}{2}$	FMG-SOC-50-40
65 x 25	$2\frac{1}{2} \times 1$	FMG-SOC-65-25
65 x 40	$2\frac{1}{2} \times 1\frac{1}{2}$	FMG-SOC-65-40
65 x 50	$2\frac{1}{2} \times 2$	FMG-SOC-65-50
80 x 50	3×2	FMG-SOC-80-50
80 x 65	$3 \times 2\frac{1}{2}$	FMG-SOC-80-65
100 x 50	4×2	FMG-SOC-100-50
100 x 65	4×2	FMG-SOC-100-65
100 x 80	4×3	FMG-SOC-100-80



Malleable Iron

Product Group: GM01

Reducing Hex Bush



Malleable Iron



Stainless Steel

Thread Size BSP		Part Numbers	
mm	inch	Malleable Iron	316 Stainless Steel
8 x 6	¼ x ⅛	FMG-BUS-8-6	SS16B0806
10 x 6	⅜ x ⅛	FMG-BUS-10-6	SS16B1006
10 x 8	⅜ x ¼	FMG-BUS-10-8	SS16B1008
15 x 6	½ x ⅛	FMG-BUS-15-6	SS16B1506
15 x 8	½ x ¼	FMG-BUS-15-8	SS16B1508
15 x 10	½ x ⅜	FMG-BUS-15-10	SS16B1510
20 x 8	¾ x ¼	FMG-BUS-20-8	SS16B2008
20 x 10	¾ x ⅜	FMG-BUS-20-10	SS16B2010
20 x 15	¾ x ½	FMG-BUS-20-15	SS16B2015
25 x 8	1 x ¼	FMG-BUS-25-8	-
25 x 10	1 x ⅜	FMG-BUS-25-10	-
25 x 15	1 x ½	FMG-BUS-25-15	SS16B2515
25 x 20	1 x ¾	FMG-BUS-25-20	SS16B2520
32 x 15	1 ¼ x ½	FMG-BUS-32-15	SS16B3215
32 x 20	1 ¼ x ¾	FMG-BUS-32-20	SS16B3220
32 x 25	1 ¼ x 1	FMG-BUS-32-25	SS16B3225
40 x 15	1 ½ x ½	FMG-BUS-40-15	SS16B4015
40 x 20	1 ½ x ¾	FMG-BUS-40-20	SS16B4020
40 x 25	1 ½ x 1	FMG-BUS-40-25	SS16B4025
40 x 32	1 ½ x 1 ¼	FMG-BUS-40-32	SS16B4032
50 x 15	2 x ½	FMG-BUS-50-15	-
50 x 20	2 x ¾	FMG-BUS-50-20	-
50 x 25	2 x 1	FMG-BUS-50-25	SS16B5025
50 x 32	2 x 1 ¼	FMG-BUS-50-32	SS16B5032
50 x 40	2 x 1 ½	FMG-BUS-50-40	SS16B5040
65 x 15	2 ½ x ½	FMG-BUS-65-15	-
65 x 25	2 ½ x 1	FMG-BUS-65-25	-
65 x 32	2 ½ x 1 ¼	FMG-BUS-65-32	-
65 x 40	2 ½ x 1 ½	FMG-BUS-65-40	-
65 x 50	2 ½ x 2	FMG-BUS-65-50	SS16B6550
80 x 25	3 x 1	FMG-BUS-80-25	-
80 x 40	3 x 1 ½	FMG-BUS-80-40	-
80 x 50	3 x 2	FMG-BUS-80-50	SS16B8050
80 x 65	3 x 2 ½	FMG-BUS-80-65	SS16B8065
100 x 50	4 x 2	FMG-BUS-100-50	SS16B100050
100 x 65	4 x 2 ½	FMG-BUS-100-65	-
100 x 80	4 x 3	FMG-BUS-100-80	SS16B10080
150 x 80	6 x 3	FMG-BUS-150-80	-
150 x 100	6 x 4	FMG-BUS-150-100	-

Product Group: GM01

Product Group: AW01

Hex Plugs

Thread Size BSP		Part Numbers	
mm	inch	Malleable Iron	316 Stainless Steel
6	1/8	FMG-HP-6	-
8	1/4	FMG-HP-8	SS16XP008
10	3/8	FMG-HP-10	SS16XP010
15	1/2	FMG-HP-15	SS16XP015
20	3/4	FMG-HP-20	SS16XP020
25	1	FMG-HP-25	SS16XP025
32	1 1/4	FMG-HP-32	SS16XP032
40	1 1/2	FMG-HP-40	SS16XP040
50	2	FMG-HP-50	SS16XP050
65	2 1/2	FMG-HP-65	SS16XP065
80	3	FMG-HP-80	SS16XP080
100	4	FMG-HP-100	SS16XP100

Product Group: GM01



Malleable Iron



Stainless Steel

Unions - Female x Female

Thread Size BSP		Part Numbers	
mm	inch	Malleable Iron	316 Stainless Steel
10	3/8	FMG-USB-10	SS16FU010
15	1/2	FMG-USB-15	SS16FU015
20	3/4	FMG-USB-20	SS16FU020
25	1	FMG-USB-25	SS16FU025
32	1 1/4	FMG-USB-32	SS16FU032
40	1 1/2	FMG-USB-40	SS16FU040
50	2	FMG-USB-50	SS16FU050
65	2 1/2	FMG-USB-65	SS16FU065
80	3	FMG-USB-80	SS16FU080
100	4	FMG-USB-100	SS16FU100

Product Group: GM01

Product Group: AW01



Malleable Iron



Stainless Steel

Backnuts

Thread Size BSP		Part Numbers
mm	inch	Malleable Iron
15	1/2	FMG-BAC-15
25	1	FMG-BAC-25
32	1 1/4	FMG-BAC-32
50	2	FMG-BAC-50
65	2 1/2	FMG-BAC-65
100	4	FMG-BAC-100

Product Group: GM01



Q

Flanges - Drilled Table D



Thread Size BSP		Part Numbers
mm	inch	Malleable Iron
15	½	FMG-FD-15
20	¾	FMG-FD-20
25	1	FMG-FD-25
32	1¼	FMG-FD-32
40	1½	FMG-FD-40
50	2	FMG-FD-50
65	2½	FMG-FD-65
80	3	FMG-FD-80
100	4	FMG-FD-100
150	6	FMG-FD-150

Product Group: GM01

Cross



Malleable Iron

Thread Size BSP		Part Numbers	
mm	inch	Malleable Iron	316 Stainless Steel
15	½	FMG-CRO-15	SS16CR015
20	¾	FMG-CRO-20	-
25	1	FMG-CRO-25	-
32	1¼	FMG-CRO-32	-
40	1½	FMG-CRO-40	-
50	2	FMG-CRO-50	-
65	2½	FMG-CRO-65	-
80	3	FMG-CRO-80	-
100	4	FMG-CRO-100	-

Product Group: GM01

Caps



Malleable Iron



Stainless Steel

Thread Size BSP		Part Numbers	
mm	inch	Malleable Iron	316 Stainless Steel
8	¼	FMG-CAP-8	-
10	⅜	FMG-CAP-10	-
15	½	FMG-CAP-15	-
20	¾	FMG-CAP-20	SS16C020
25	1	FMG-CAP-25	SS16C025
32	1¼	FMG-CAP-32	SS16C032
40	1½	FMG-CAP-40	SS16C040
50	2	FMG-CAP-50	SS16C050
65	2½	FMG-CAP-65	-
80	3	FMG-CAP-80	SS16C080
100	4	FMG-CAP-100	SS16C100

Product Group: GM01

Product Group: AW01

Reducing Male BSP Hose Tails

Male BSP		Hose Tail		Part Numbers
mm	inch	mm	inch	316 Stainless Steel
15	½	20	¾	SS16HTR1520
20	¾	15	½	SS16HTR2015
20	¾	16	⅝	SS16HTR2016
25	1	16	⅝	SS16HTR2516
25	1	20	¾	SS16HTR2520
40	1½	32	1¼	SS16HTR4032
50	2	40	1½	SS16HTR5040
50	1	45	1¾	SS16HTR5045
65	2½	50	2	SS16HTR6550
80	3	65	2½	SS16HTR8065
100	4	80	3	SS16HTR10080

Product Group: AW01



Male BSP Hose Tails

Male BSP		Hose Tail		Part Numbers
mm	inch	mm	inch	316 Stainless Steel
6	⅛	6	⅛	SS16HT006
8	¼	8	¼	SS16HT008
10	⅜	10	⅜	SS16HT010
15	½	15	½	SS16HT015
20	¾	20	¾	SS16HT020
25	1	25	1	SS16HT025
32	1¼	32	1¼	SS16HT032
40	1½	40	1½	SS16HT040
50	2	50	2	SS16HT050
65	2½	65	2½	SS16HT065
80	3	80	3	SS16HT080
100	4	100	4	SS16HT0100
150	6	150	6	SS16HT0150

Product Group: AW01



Toe Weld Nipples

Thread Size BSP		Part Numbers
mm	inch	316 Stainless Steel
10	⅜	SS16TN010
15	½	SS16TN015
20	¾	SS16TN020
25	1	SS16TN025
32	1¼	SS16TN032
40	1½	SS16TN040
50	2	SS16TN050
65	2½	SS16TN065
80	3	SS16TN080
100	4	SS16TN010

Product Group: AW01



